

A Control Strategy for a Variable Speed Wind Turbine with a Permanent-Magnet Synchronous Generator

Digreshwar D. Barbuddhe

Department of Electrical Engineering, DES's COET Dhamangaon, Rly.

Rahul M. Didpaye

Department of Electrical Engineering, DES's COET Dhamangaon, Rly.

Ashvini B. Nagdewate

Assistant Prof. Dept. of Electrical (Electronics & Power) Engineering, DES's COET Dhamangaon Rly.

Abstract – We know the electrical power is generated by using wind energy to drive a wind turbine. Due to their tremendous applications and advantages. This paper presents a novel control strategy for the operation of a direct-drive permanent-magnet synchronous generator- based stand-alone variable-speed wind turbine. The control strategy for the generator-side converter with maximum power extraction is presented. The stand-alone control is featured with output voltage and frequency controller that is capable of handling variable load. The potential excess of power is dissipated in the dump-load resistor with the chopper control, and the dc-link voltage is maintained. Dynamic representation of dc bus and small-signal analysis is presented. The controller shows very good dynamic and steady-state performance. The controllers can extract maximum power and regulate the voltage and frequency under varying wind and load conditions.

Index Terms – Maximum power extraction, permanent-magnet Synchronous generator (PMSG), switch-mode rectifier, variable-speed wind turbine, voltage and frequency control.

1. INTRODUCTION

Wind energy is clean silent and emission-free source of energy. Using small wind energy conversion system increases rapidly nowadays all over the world due to its availability, small size, high performances, low cost installation, and it has low weight compared to induction generators. PMSG is used more frequently in small wind turbine application due to its robustness, reliability and high efficiency when connected to variable speed wind turbine [1]. Most papers [2], [3], [4] are considering using PMSG and normally include controlled three phase ac to dc conversion and to extract maximum power from the fluctuating wind, variable-speed operation of the wind-turbine generator is necessary besides achieving unity power factor at the generator side. The dc/ac inverter is used to regulate the load voltage and frequency and for stand-alone systems. Additionally, a battery power flow controller is used to balance the load power as the wind power changes [3], [4].

A control strategy for the generator-side converter with output maximization of a PMSG-based small-scale wind turbine is developed. The generator-side switch-mode rectifier is controlled to achieve maximum power from the wind. The stand-alone control is featured with output voltage and frequency controller capable of handling variable load. A dump-load-resistor controller is used to dissipate excess power during fault or over generation. The excess power is dissipated in the dump-load resistor with the chopper control, and the dc-link voltage is maintained.

2. SYSTEM OVERVIEW

In this paper, a single-switch three-phase switch-mode rectifier is used to convert the ac output voltage of the generator to a constant dc voltage before conversion to ac voltage via an inverter. The single-switch three-phase switch-mode rectifier consists of a three-phase diode bridge rectifier and a dc to dc converter. The output of the switch-mode rectifier can be controlled by controlling the duty cycle of an active switch (such as IGBT) at any wind speed to extract maximum power from the wind turbine and to supply the loads. The Fig. shows the control structure of a PMSG-based standalone variable-speed wind turbine which includes a wind turbine, PMSG, single-switch three-phase switch-mode rectifier, and a vector-controlled PWM voltage-source inverter. Voltage drop due to sudden fall in wind speed can be compensated by the energy-storage system. During wind gust, the dump-load controller will be activated to regulate the dc-link voltage to maintain the output load voltage at the desired value.

3. CONTROL OF SWITCH-MODE RECTIFIER WITH MAXIMUM POWER EXTRACTION

This section describes the main techniques that have been reported to the control of wind turbine toward the maximization the output power. To allow the turbine to transfer a maximum

fraction of available wind power for fluctuating wind velocities incident upon the turbine blades, it is desirable to maintain the tip-speed ratio at point of maximum power coefficient $cp(\lambda)$. Based in this principle several control techniques have been developed to optimize output power for a given wind velocity. Other techniques employed a Maximum Power Point Tracking (MPPT) algorithm with search for the turbine rotating speed, which result in the maximum power, is based on a measurement of the power generated. Therefore, since the measurement of the power generated is simpler and more accurate than the measurement of the wind velocity, the MPPT is preferred.

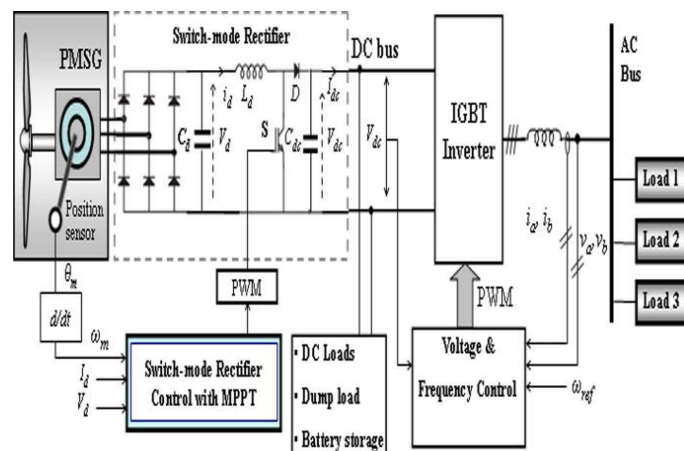

Fig .Control structure of a PMSG Based Stand-alone Variable-Speed Wind turbine

The generator torque is controlled in the optimum torque curve according to the generator speed. The acceleration or deceleration of the generator is determined by the difference of the turbine torque T_m and generator torque T_g . If the generator speed is less than the optimal speed, the turbine torque is larger than the generator torque, and the generator will be accelerated. The generator will be decelerated if the generator speed is higher than the optimal speed. Therefore, the turbine and generator torques settle down to the optimum torque point T_{m_opt} at any wind speed, and the wind turbine is operated at the maximum power point.

4. CONTROL OF LOAD-SIDE INVERTER

The control strategy of Vector-Control Scheme is used to perform the control of the grid side converter. They control of the DC-link voltage, active and reactive power delivered to the grid, grid synchronization and to ensure high quality of the injected power [2].The objective of the supply-side converter is to regulate the voltage and frequency. The control schemes are in the inner loops where they use different reference frames to perform the current control. In the first case, the currents are controlled in the synchronous rotating reference frame using PI controllers. The dc voltage PI controller maintains the dc voltage to the reference value. The PI controllers are used to

regulate the output voltage and currents in the inner control loops and the dc voltage controller in the outer loop. This is the classical control structure, it is also known as dq-control. It transforms the grid voltages and currents from the abc to the dq reference frame. In this way the variables are transformed to DC values which can be controlled more easily. This structure uses PI controllers since they have good performance for controlling DC variable.

5. RESULTS FOR PROPOSED SYSTEM

The model of the PMSG-based variable-speed wind-turbine system of Fig. is built using Matlab/ Simpower dynamic system simulation software

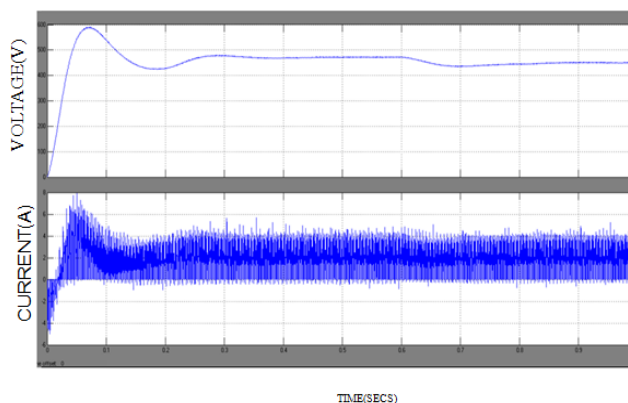

Fig.: Inverter –side control

6. ADVANTAGES

1. Maintenance cost is low
2. It can be installed in small area.
3. It doesn't produce any emission.
4. It is distributed power generation application.
5. It has complete control of active and reactive power.

7. DISADVANTAGES

1. Installation cost is high.
2. In winter season there is small amount of wind is available.

8. APPLICATIONS

1. For the grid connection.
2. Domestic purpose.
3. In agricultural purpose.

9. CONCLUSIONS

In this way, discuss the basic terms used in the paper and its control using the dc/ac inverter. A control strategy for a direct-drive stand-alone variable speed wind turbine with a PMSG has

been presented in this project. A simple control strategy for the generator-side converter to extract maximum power is discussed and implemented using Simpower dynamic-system simulation software. The controller is capable of maximizing output of the variable-speed wind turbine under fluctuating wind. The generating system with the proposed control strategy is suitable for a small-scale stand-alone variable-speed wind-turbine installation for remote-area power supply. The simulation results demonstrate that the controller works very well and shows very good dynamic and steady-state performance.

REFERENCES

- [1] Munteanu, A. Bratcu, I. and Ceanga, E. (2009) "wind turbulence used as searching signal for MPPT in variable-speed wind energy conversion systems," *Renew. Energy*, Vol.34, pp.322-327.
- [2] R. Hoffmann and P. Mutschler, "The influence of control strategies on energy capture of wind turbines," in *Proc. 35th IAS Annu. Meeting World Conf. Ind. Applicat. Elect. Energy*, Piscataway, NJ, 2000, pp. 886–893.
- [3] Chan, T. F. and Lai, L. L. (2007), "Permanent-magnet machines for distributed generation: A review," in *Proc. IEEE Power Eng. Annu. Meeting*, pp. 1–6.
- [4] M. Heydari, A Yazdian, M. Mohamadian, "A Novel Three-Phase to Three Phase AC/AC Converter Using Six IGBTs", *EPECS II, UAE, 20 II*